

The information contained in this drawing is the sole property of CWS Coil Winding Specialist. Any reproduction in part or whole without written permission of CWS Coil Winding Specialist is prohibited.

REVISION HISTORY

REV	ECN	DESCRIPTION	SIGN & DATE			
			BY	DATE	CHK	DATE
B		PRODUCTION RELEASE	TDK	5/08/06	JLJU	5/08/06

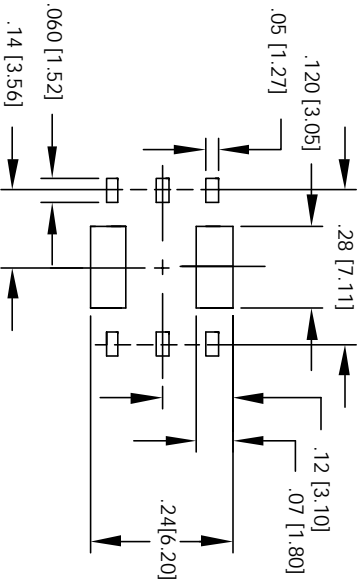
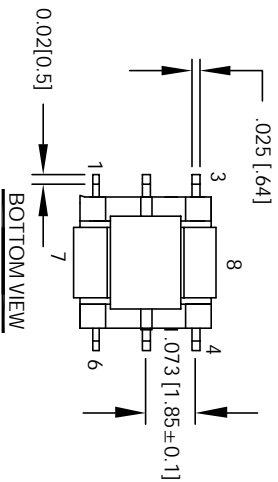
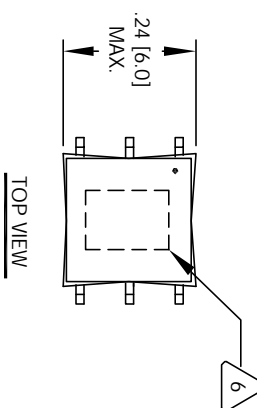
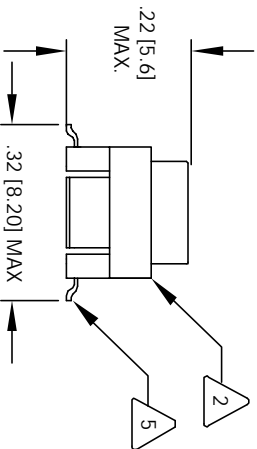
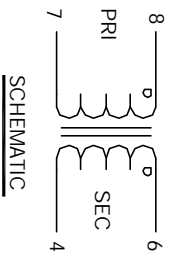

6 WHERE SHOWN
MARK PART NUMBER AND REVISION

5 REMOVE INSULATION, SOLDERED TO LEADS

- 4 CONSTRUCTION: ENCAPSULATED USING BOBBIN.
 FREQUENCY RANGE AT 100 KHZ AND ABOVE
 OPERATING TEMP. = - 25 °C TO 125 °C
 HI-POT PRIMARY TO SECONDARY = 500 Vrms
 PRIMARY CURRENT = 6 A MAX.
 SECONDARY DCR = 1.14 OHMS MAX
 SECONDARY INDUCTANCE@ 10 KHZ, 0.1 V = 320.0 uH MIN
 TURNS RATIO PRI:SEC = 1:40
- 3 SPECIFICATIONS @ 25 °C :

2 WIRE: UL RECOGNIZED 130 °C RATED MAGNET WIRE
 CWS BYTE MARK OR OTHER APPROVED PART
 CORE: FERRITE TOROID

- 1 BOBBIN RATING CLASS B (130 °C.) REQUIRED
 MATERIAL: UL RECOGNIZED 94V-0 FOR FLAMMABILITY
- NOTES: UNLESS OTHERWISE SPECIFIED, CURRENT SENSOR.
 UNIT: INCHES [MM]
 READ FROM BOTTOM UP

UNLESS OTHERWISE SPECIFIED
DIMENSIONING AND TOLERANCE PER ANSI Y14.4M
ALL DIMENSIONS ARE IN INCHES AND [DIMENSIONS]
TOLERANCE INCHES: .XXX = ±.010 .XX = ±.020 .X = ±.030
TOLERANCE METRCS: .XXX = ±.254 .XX = ±.51
ANGLE PROJECTION
DO NOT SCALE DRAWING

QTY	CODE	IDENT	MFG. P/N	DESCRIPTION	ITEM NO.
	AUTOCAD	X			
	SOLIDWORKS				
	SIGN	DATE			
	DRWN	RRP	5/08/06		
	ENGR	JLJU	5/08/06		
	APPR	JLJU	5/08/06		
	SCALE	B	SIZE [DIM. IN.]	72-302	REV B
		4=1			

PARTS LIST

COLIWS.COM, INC
 WWW.COLIWS.COM
 353 W. GROVE AVENUE
 ORANGE, CA. 92665

Current Sense Transformer